

PVC-U metric

Cone check valves

Check valve type 561 PVC-U With solvent cement sockets metric



Model:

- Designed for easy installation and removal
- Sealing at a minimum water column of 2m
- Vibration free even at high flow velocity
- Flow-optimized return cone, double guided
- For horizontal or vertical installation
- Compact installation length, same as ball valve type 546
- Z-length, end connectors and union nuts **not** compatible with type 360
- New DN65-DN100

Available from 2nd quarter 2011

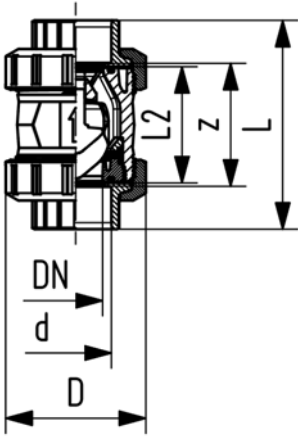

d [mm]	DN [mm]	PN	kv-value (Δp=1 bar) [l/min]	EPDM Code	FPM Code	D [mm]	L [mm]	L2 [mm]	z [mm]	closest inch
16	10	16	190	161 561 001	161 561 011	50	92	56	64	3/8
20	15	16	180	161 561 002	161 561 012	50	95	56	64	1/2
25	20	16	380	161 561 003	161 561 013	58	110	65	72	3/4
32	25	16	460	161 561 004	161 561 014	68	123	71	79	1
40	32	16	850	161 561 005	161 561 015	84	146	85	94	1 1/4
50	40	16	1080	161 561 006	161 561 016	97	157	89	95	1 1/2
63	50	16	1670	161 561 007	161 561 017	124	183	101	107	2
75	65	16	2950	161 561 008	161 561 018	166	233	136	144	2 1/2
90	80	16	3600	161 561 009	161 561 019	200	254	141	151	3
110	100	16	4150	161 561 010	161 561 020	238	301	164	174	4

Check valve type 561 PVC-U With solvent cement spigots metric



Model:

- Designed for easy installation and removal
- Sealing at a minimum water column of 2m
- Vibration free even at high flow velocity
- Flow-optimized return cone, double guided
- For horizontal or vertical installation
- Compact installation length, same as ball valve type 546
- Z-length, end connectors and union nuts **not** compatible with type 360
- New DN65-DN100

Available from 2nd quarter 2011

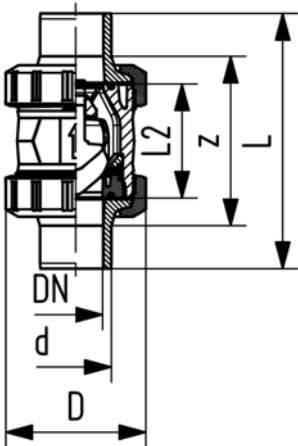

d [mm]	DN [mm]	PN	kv-value (Δp=1 bar) [l/min]	EPDM Code	FPM Code	D [mm]	L [mm]	L2 [mm]	closest inch
16	10	16	190	161 561 041	161 561 051	50	114	56	3/8
20	15	16	180	161 561 042	161 561 052	50	124	56	1/2
25	20	16	380	161 561 043	161 561 053	58	144	65	3/4
32	25	16	460	161 561 044	161 561 054	68	154	71	1
40	32	16	850	161 561 045	161 561 055	84	174	85	1 1/4
50	40	16	1080	161 561 046	161 561 056	97	194	89	1 1/2
63	50	16	1670	161 561 047	161 561 057	124	224	101	2
75	65	16	2950	161 561 048	161 561 058	166	284	136	2 1/2
90	80	16	3600	161 561 049	161 561 059	200	300	141	3
110	100	16	4150	161 561 050	161 561 060	238	340	164	4

PVC-U metric

Check valve type 561 PVC-U With threaded sockets Rp



Model:

- Designed for easy installation and removal
- Sealing at a minimum water column of 2m
- Vibration free even at high flow velocity
- Flow-optimized return cone, double guided
- For horizontal or vertical installation
- Compact installation length, same as ball valve type 546
- Z-length, end connectors and union nuts **not** compatible with type 360
- New DN65-DN100

Available from 2nd quarter 2011

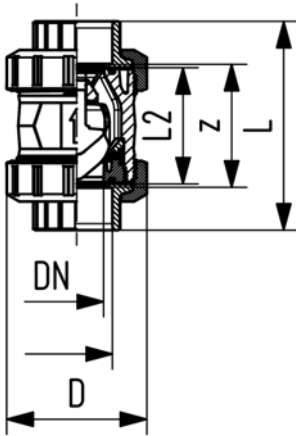

Rp [inch]	DN [mm]	PN	kv-value ($\Delta p=1$ bar) [l/min]	EPDM Code	FPM Code	D [mm]	L [mm]	L2 [mm]	z [mm]
3/8	10	10	190	161 561 021	161 561 031	50	95	56	69
1/2	15	10	180	161 561 022	161 561 032	50	100	56	67
3/4	20	10	380	161 561 023	161 561 033	58	114	65	78
1	25	10	460	161 561 024	161 561 034	68	127	71	85
1 1/4	32	10	850	161 561 025	161 561 035	84	146	85	100
1 1/2	40	10	1080	161 561 026	161 561 036	97	152	89	106
2	50	10	1670	161 561 027	161 561 037	124	177	101	121
2 1/2	65	10	2950	161 561 028	161 561 038	166	233	136	144
3	80	10	3600	161 561 029	161 561 039	200	254	141	151
4	100	10	4150	161 561 030	161 561 040	238	301	164	174

Check valve type 561 PVC-U With fixed flanges metric



Model:

- Designed for easy installation and removal
- Sealing at a minimum water column of 2m
- Vibration free even at high flow velocity
- Flow-optimized return cone, double guided
- For horizontal or vertical installation
- Compact installation length, same as ball valve type 546
- Z-length, end connectors and union nuts **not** compatible with type 360
- Installation length according to EN 558-1
- Connecting dimension: ISO 7005 PN10, EN 1092 PN10, DIN 2501 PN10

Available from 2nd quarter 2011

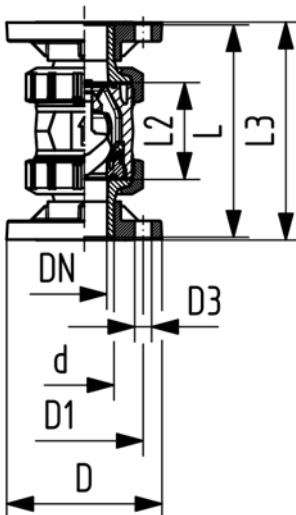

d [mm]	DN [mm]	PN	kv-value ($\Delta p=1$ bar) [l/min]	EPDM Code	FPM Code
20	15	16	180	161 561 082	161 561 092
25	20	16	380	161 561 083	161 561 093
32	25	16	460	161 561 084	161 561 094
40	32	16	850	161 561 085	161 561 095
50	40	16	1080	161 561 086	161 561 096
63	50	16	1670	161 561 087	161 561 097

d [mm]	D [mm]	D1 [mm]	D3 [mm]	L [mm]	L2 [mm]	L3 [mm]	closest inch
20	95	65	14	124	56	130	1/2
25	105	75	14	144	65	150	3/4
32	115	85	14	154	71	160	1
40	140	100	18	174	85	180	1 1/4
50	150	110	18	194	89	200	1 1/2
63	165	125	18	224	101	230	2

PVC-U metric

Check valve type 561 PVC-U With butt fusion spigots long PE100 SDR11 metric



Model:

- Designed for easy installation and removal
- Sealing at a minimum water column of 2m
- Vibration free even at high flow velocity
- Flow-optimized return cone, double guided
- For horizontal or vertical installation
- Compact installation length, same as ball valve type 546
- Z-length, end connectors and union nuts **not** compatible with type 360

Available from 2nd quarter 2011

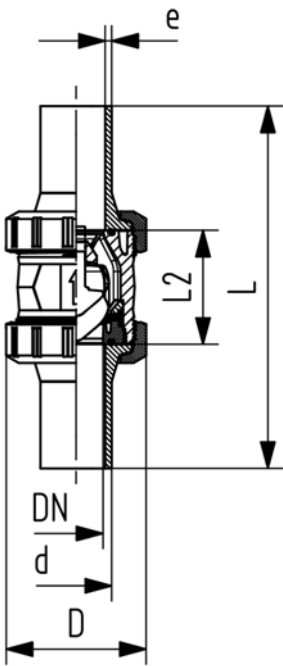

d [mm]	DN [mm]	PN	kv-value ($\Delta p=1$ bar) [l/min]	EPDM Code	D [mm]	L [mm]	L2 [mm]	e [mm]	closest inch
20	15	16	180	161 561 142	50	193	56	2.3	1/2
25	20	16	380	161 561 143	58	216	65	2.3	3/4
32	25	16	460	161 561 144	68	223	71	3.0	1
40	32	16	850	161 561 145	84	249	85	3.7	1 1/4
50	40	16	1080	161 561 146	97	271	89	4.6	1 1/2
63	50	16	1670	161 561 147	124	321	101	5.8	2

PVC-U metric

Check valve type 562 PVC-U With solvent cement sockets metric



Model:

- Spring loaded, spring made of stainless steel (1.4310)
- Spring available in other materials, see spare parts
- Designed for easy installation and removal
- Sealing at a minimum water column of 0.5m
- Vibration free even at high flow velocity
- Flow-optimized return cone, double guided
- For horizontal or vertical installation
- Compact installation length, same as ball valve type 546
- Z-length, end connectors and union nuts **not** compatible with type 360
- New DN65-DN100

Available from 2nd quarter 2011

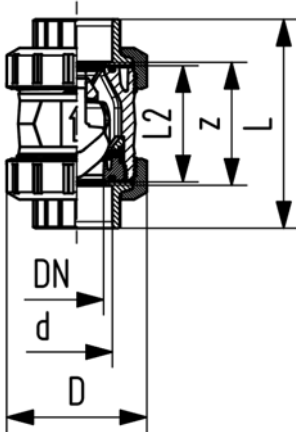

d [mm]	DN [mm]	PN	kv-value ($\Delta p=1$ bar) [l/min]	EPDM Code	FPM Code	D [mm]	L [mm]	L2 [mm]	z [mm]	closest inch
16	10	16	190	161 562 001	161 562 011	50	92	56	64	3/8
20	15	16	180	161 562 002	161 562 012	50	95	56	64	1/2
25	20	16	380	161 562 003	161 562 013	58	110	65	72	3/4
32	25	16	460	161 562 004	161 562 014	68	123	71	79	1
40	32	16	850	161 562 005	161 562 015	84	146	85	94	1 1/4
50	40	16	1080	161 562 006	161 562 016	97	157	89	95	1 1/2
63	50	16	1670	161 562 007	161 562 017	124	183	101	107	2
75	65	16	2950	161 562 008	161 562 018	166	233	136	144	2 1/2
90	80	16	3600	161 562 009	161 562 019	200	254	141	151	3
110	100	16	4150	161 562 010	161 562 020	238	301	164	174	4

Check valve type 562 PVC-U With solvent cement spigots metric



Model:

- Spring loaded, spring made of stainless steel (1.4310)
- Spring available in other materials, see spare parts
- Designed for easy installation and removal
- Sealing at a minimum water column of 0.5m
- Vibration free even at high flow velocity
- Flow-optimized return cone, double guided
- For horizontal or vertical installation
- Compact installation length, same as ball valve type 546
- Z-length, end connectors and union nuts **not** compatible with type 360
- New DN65-DN100

Available from 2nd quarter 2011

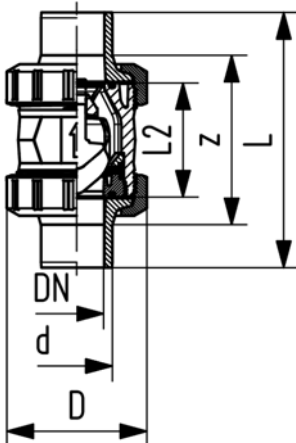

d [mm]	DN [mm]	PN	kv-value ($\Delta p=1$ bar) [l/min]	EPDM Code	FPM Code	D [mm]	L [mm]	L2 [mm]	closest inch
16	10	16	190	161 562 041	161 562 051	50	114	56	3/8
20	15	16	180	161 562 042	161 562 052	50	124	56	1/2
25	20	16	380	161 562 043	161 562 053	58	144	65	3/4
32	25	16	460	161 562 044	161 562 054	68	154	71	1
40	32	16	850	161 562 045	161 562 055	84	174	85	1 1/4
50	40	16	1080	161 562 046	161 562 056	97	194	89	1 1/2
63	50	16	1670	161 562 047	161 562 057	124	224	101	2
75	65	16	2950	161 562 048	161 562 058	166	284	136	2 1/2
90	80	16	3600	161 562 049	161 562 059	200	300	141	3
110	100	16	4150	161 562 050	161 562 060	238	340	164	4

PVC-U metric

Check valve type 562 PVC-U With threaded sockets Rp

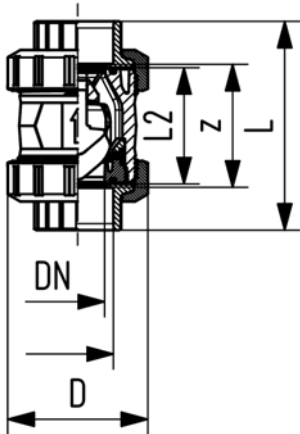

Model:

- Spring loaded, spring made of stainless steel (1.4310)
- Spring available in other materials, see spare parts
- Designed for easy installation and removal
- Sealing at a minimum water column of 0.5m
- Vibration free even at high flow velocity
- Flow-optimized return cone, double guided
- For horizontal or vertical installation
- Compact installation length, same as ball valve type 546
- Z-length, end connectors and union nuts **not** compatible with type 360
- New DN65-DN100

Available from 2nd quarter 2011

Rp [inch]	DN [mm]	PN	kv-value ($\Delta p=1$ bar) [l/min]	EPDM Code	FPM Code	D [mm]	L [mm]	L2 [mm]	z [mm]
3/8	10	10	190	161 562 021	161 562 031	50	95	56	69
1/2	15	10	180	161 562 022	161 562 032	50	100	56	67
3/4	20	10	380	161 562 023	161 562 033	58	114	65	78
1	25	10	460	161 562 024	161 562 034	68	127	71	85
1 1/4	32	10	850	161 562 025	161 562 035	84	146	85	100
1 1/2	40	10	1080	161 562 026	161 562 036	97	152	89	106
2	50	10	1670	161 562 027	161 562 037	124	177	101	121
2 1/2	65	10	2950	161 562 028	161 562 038	166	233	136	144
3	80	10	3600	161 562 029	161 562 039	200	254	141	151
4	100	10	4150	161 562 030	161 562 040	238	301	164	174

Check valve type 562 PVC-U With fixed flanges metric

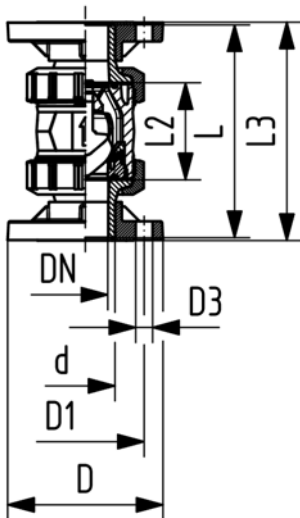

Model:

- Spring loaded, spring made of stainless steel (1.4310)
- Spring available in other materials, see spare parts
- Designed for easy installation and removal
- Sealing at a minimum water column of 0.5m
- Vibration free even at high flow velocity
- Flow-optimized return cone, double guided
- For horizontal or vertical installation
- Compact installation length, same as ball valve type 546
- Z-length, end connectors and union nuts **not** compatible with type 360
- Installation length according to EN 558-1
- Connecting dimension: ISO 7005 PN10, EN 1092 PN10, DIN 2501 PN10

Available from 2nd quarter 2011

d [mm]	DN [mm]	PN	kv-value ($\Delta p=1$ bar) [l/min]	EPDM Code	FPM Code
20	15	16	180	161 562 082	161 562 092
25	20	16	380	161 562 083	161 562 093
32	25	16	460	161 562 084	161 562 094
40	32	16	850	161 562 085	161 562 095
50	40	16	1080	161 562 086	161 562 096
63	50	16	1670	161 562 087	161 562 097

table continued next page

PVC-U metric

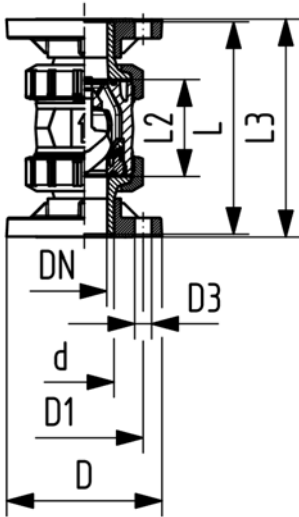

d [mm]	D [mm]	D1 [mm]	D3 [mm]	L [mm]	L2 [mm]	L3 [mm]	closest inch
20	95	65	14	124	56	130	½
25	105	75	14	144	65	150	¾
32	115	85	14	154	71	160	1
40	140	100	18	174	85	180	1 ¼
50	150	110	18	194	89	200	1 ½
63	165	125	18	224	101	230	2



Check valve type 562 PVC-U With butt fusion spigots long PE100 SDR11 metric



Model:

- Spring loaded, spring made of stainless steel (1.4310)
- Spring available in other materials, see spare parts
- Designed for easy installation and removal
- Sealing at a minimum water column of 0.5m
- Vibration free even at high flow velocity
- Flow-optimized return cone, double guided
- For horizontal or vertical installation
- Compact installation length, same as ball valve type 546
- Z-length, end connectors and union nuts **not** compatible with type 360

Available from 2nd quarter 2011

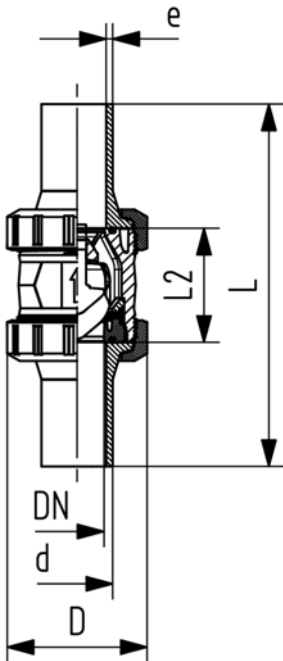

d [mm]	DN [mm]	PN	kv-value ($\Delta p=1$ bar) [l/min]	EPDM Code	D [mm]	L [mm]	L2 [mm]	e [mm]	closest inch
20	15	16	180	161 562 142	50	193	56	2.3	½
25	20	16	380	161 562 143	58	216	65	2.3	¾
32	25	16	460	161 562 144	68	223	71	3.0	1
40	32	16	850	161 562 145	84	249	85	3.7	1 ¼
50	40	16	1080	161 562 146	97	271	89	4.6	1 ½
63	50	16	1670	161 562 147	124	321	101	5.8	2

PVC-U metric silicone free Paintcompatible and oil free Cone check valves

Check valve type 561 PVC-U SF With solvent cement sockets metric



Model:

- Silicone free / paint-compatible
- Designed for easy installation and removal
- Sealing at a minimum water column of 2m
- Vibration free even at high flow velocity
- Flow-optimized return cone, double guided
- For horizontal or vertical installation
- Compact installation length, same as ball valve type 546
- Z-length, end connectors and union nuts **not** compatible with type 360
- New DN65-DN100

Available from 2nd quarter 2011

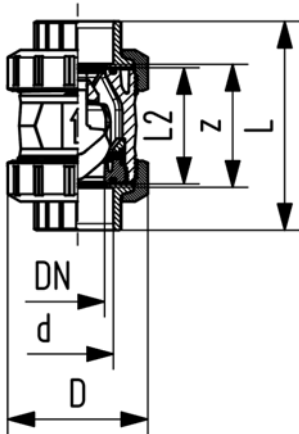

d [mm]	DN [mm]	PN	kv-value ($\Delta p=1$ bar) [l/min]	EPDM Code	FPM Code	D [mm]	L [mm]	L2 [mm]	z [mm]	closest inch
16	10	16	190	161 561 201	161 561 211	50	92	56	64	3/8
20	15	16	180	161 561 202	161 561 212	50	95	56	64	1/2
25	20	16	380	161 561 203	161 561 213	58	110	65	72	3/4
32	25	16	460	161 561 204	161 561 214	68	123	71	79	1
40	32	16	850	161 561 205	161 561 215	84	146	85	94	1 1/4
50	40	16	1080	161 561 206	161 561 216	97	157	89	95	1 1/2
63	50	16	1670	161 561 207	161 561 217	124	183	101	107	2
75	65	16	2950	161 561 208	161 561 218	166	233	136	144	2 1/2
90	80	16	3600	161 561 209	161 561 219	200	254	141	151	3
110	100	16	4150	161 561 210	161 561 220	238	301	164	174	4

Check valve type 561 PVC-U SF With solvent cement spigots metric



Model:

- Silicone free / paint-compatible
- Designed for easy installation and removal
- Sealing at a minimum water column of 2m
- Vibration free even at high flow velocity
- Flow-optimized return cone, double guided
- For horizontal or vertical installation
- Compact installation length, same as ball valve type 546
- Z-length, end connectors and union nuts **not** compatible with type 360
- New DN65-DN100

Available from 2nd quarter 2011

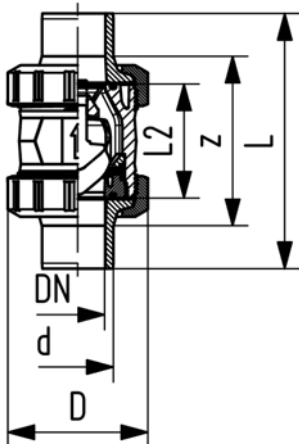

d [mm]	DN [mm]	PN	kv-value ($\Delta p=1$ bar) [l/min]	EPDM Code	FPM Code	D [mm]	L [mm]	L2 [mm]	closest inch
16	10	16	190	161 561 221	161 561 231	50	114	56	3/8
20	15	16	180	161 561 222	161 561 232	50	124	56	1/2
25	20	16	380	161 561 223	161 561 233	58	144	65	3/4
32	25	16	460	161 561 224	161 561 234	68	154	71	1
40	32	16	850	161 561 225	161 561 235	84	174	85	1 1/4
50	40	16	1080	161 561 226	161 561 236	97	194	89	1 1/2
63	50	16	1670	161 561 227	161 561 237	124	224	101	2
75	65	16	2950	161 561 228	161 561 238	166	284	136	2 1/2
90	80	16	3600	161 561 229	161 561 239	200	300	141	3
110	100	16	4150	161 561 230	161 561 240	238	340	164	4

PVC-U metric silicone free

Paintcompatible and oil free Check valve type 562 PVC-U SF With solvent cement sockets metric

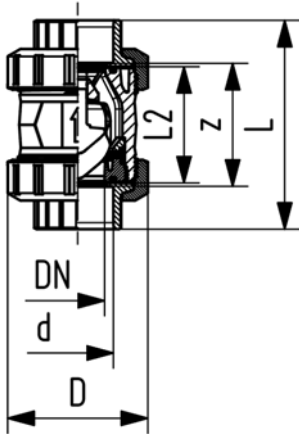

Model:

- Silicone free / paint-compatible
- Spring loaded, spring made of stainless steel (1.4310)
- Spring available in other materials, see spare parts
- Designed for easy installation and removal
- Sealing at a minimum water column of 0.5m
- Vibration free even at high flow velocity
- Flow-optimized return cone, double guided
- For horizontal or vertical installation
- Compact installation length, same as ball valve type 546
- Z-length, end connectors and union nuts **not** compatible with type 360
- New DN65-DN100

Available from 2nd quarter 2011

d [mm]	DN [mm]	PN	kv-value ($\Delta p=1$ bar) [l/min]	EPDM Code	FPM Code	D [mm]	L [mm]	L2 [mm]	z [mm]	closest inch
16	10	16	190	161 562 201	161 562 211	50	92	56	64	3/8
20	15	16	180	161 562 202	161 562 212	50	95	56	64	1/2
25	20	16	380	161 562 203	161 562 213	58	110	65	72	3/4
32	25	16	460	161 562 204	161 562 214	68	123	71	79	1
40	32	16	850	161 562 205	161 562 215	84	146	85	94	1 1/4
50	40	16	1080	161 562 206	161 562 216	97	157	89	95	1 1/2
63	50	16	1670	161 562 207	161 562 217	124	183	101	107	2
75	65	16	2950	161 562 208	161 562 218	166	233	136	144	2 1/2
90	80	16	3600	161 562 209	161 562 219	200	254	141	151	3
110	100	16	4150	161 562 210	161 562 220	238	301	164	174	4

Check valve type 562 PVC-U SF With solvent cement spigots metric

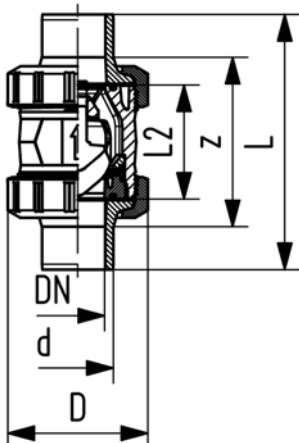

Model:

- Silicone free / paint-compatible
- Spring loaded, spring made of stainless steel (1.4310)
- Spring available in other materials, see spare parts
- Designed for easy installation and removal
- Sealing at a minimum water column of 0.5m
- Vibration free even at high flow velocity
- Flow-optimized return cone, double guided
- For horizontal or vertical installation
- Compact installation length, same as ball valve type 546
- Z-length, end connectors and union nuts **not** compatible with type 360
- New DN65-DN100

Available from 2nd quarter 2011

d [mm]	DN [mm]	PN	kv-value ($\Delta p=1$ bar) [l/min]	EPDM Code	FPM Code	D [mm]	L [mm]	L2 [mm]	closest inch
16	10	16	190	161 562 221	161 562 231	50	114	56	3/8
20	15	16	180	161 562 222	161 562 232	50	124	56	1/2
25	20	16	380	161 562 223	161 562 233	58	144	65	3/4
32	25	16	460	161 562 224	161 562 234	68	154	71	1
40	32	16	850	161 562 225	161 562 235	84	174	85	1 1/4
50	40	16	1080	161 562 226	161 562 236	97	194	89	1 1/2
63	50	16	1670	161 562 227	161 562 237	124	224	101	2
75	65	16	2950	161 562 228	161 562 238	166	284	136	2 1/2
90	80	16	3600	161 562 229	161 562 239	200	300	141	3
110	100	16	4150	161 562 230	161 562 240	238	340	164	4

PVC-U Inch BS

Cone check valves

Check valve type 561 PVC-U With solvent cement sockets Inch BS



Model:

- Designed for easy installation and removal
- Sealing at a minimum water column of 2m
- Vibration free even at high flow velocity
- Flow-optimized return cone, double guided
- For horizontal or vertical installation
- Compact installation length, same as ball valve type 546
- Z-length, end connectors and union nuts **not** compatible with type 360
- New DN65-DN100

Available from 2nd quarter 2011

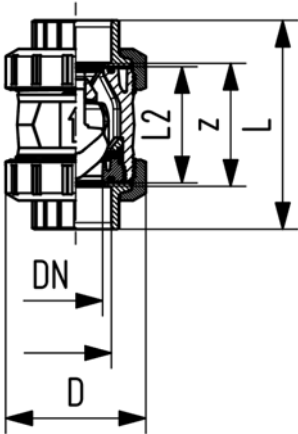

Inch	DN [mm]	PN	kv-value ($\Delta p=1$ bar) [l/min]	EPDM Code	FPM Code	D [mm]	L [mm]	L2 [mm]	z [mm]
3/8	10	16	190	161 561 061	161 561 071	50	92	56	60
1/2	15	16	180	161 561 062	161 561 072	50	95	56	60
3/4	20	16	380	161 561 063	161 561 073	58	110	65	69
1	25	16	460	161 561 064	161 561 074	68	123	71	75
1 1/4	32	16	850	161 561 065	161 561 075	84	146	85	89
1 1/2	40	16	1080	161 561 066	161 561 076	97	157	89	97
2	50	16	1670	161 561 067	161 561 077	124	183	101	110
2 1/2	65	16	2950	161 561 068	161 561 078	166	233	136	144
3	80	16	3600	161 561 069	161 561 079	200	254	141	151
4	100	16	4150	161 561 070	161 561 080	238	301	164	174

Check valve type 562 PVC-U With solvent cement sockets Inch BS



Model:

- Spring loaded, spring made of stainless steel (1.4310)
- Spring available in other materials, see spare parts
- Designed for easy installation and removal
- Sealing at a minimum water column of 0.5m
- Vibration free even at high flow velocity
- Flow-optimized return cone, double guided
- For horizontal or vertical installation
- Compact installation length, same as ball valve type 546
- Z-length, end connectors and union nuts **not** compatible with type 360
- New DN65-DN100

Available from 2nd quarter 2011

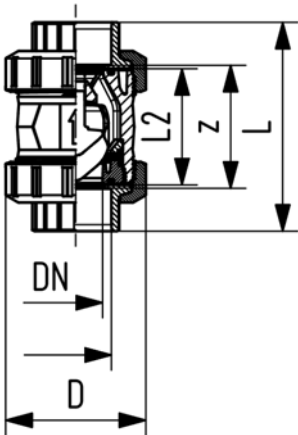

Inch	DN [mm]	PN	kv-value ($\Delta p=1$ bar) [l/min]	EPDM Code	FPM Code	D [mm]	L [mm]	L2 [mm]	z [mm]
3/8	10	16	190	161 562 061	161 562 071	50	92	56	60
1/2	15	16	180	161 562 062	161 562 072	50	95	56	60
3/4	20	16	380	161 562 063	161 562 073	58	110	65	69
1	25	16	460	161 562 064	161 562 074	68	123	71	75
1 1/4	32	16	850	161 562 065	161 562 075	84	146	85	89
1 1/2	40	16	1080	161 562 066	161 562 076	97	157	89	97
2	50	16	1670	161 562 067	161 562 077	124	183	101	110
2 1/2	65	16	2950	161 562 068	161 562 078	166	233	136	144
3	80	16	3600	161 562 069	161 562 079	200	254	141	151
4	100	16	4150	161 562 070	161 562 080	238	301	164	174

PVC-U ASTM/ANSI

Cone check valves

Check valve type 561 PVC-U With solvent cement sockets Inch ASTM Inclusive 2 threaded valve ends NPT



Model:

- Designed for easy installation and removal
- Sealing at a minimum water column of 2m
- Vibration free even at high flow velocity
- Flow-optimized return cone, double guided
- For horizontal or vertical installation
- Compact installation length, same as ball valve type 546
- Z-length, end connectors and union nuts **not** compatible with type 360
- New DN65-DN100

Available from 2nd quarter 2011

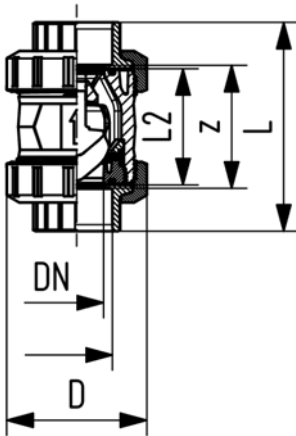

NPT [inch]	DN [mm]	PN	kv-value ($\Delta p=1$ bar) [l/min]	EPDM Code	FPM Code	D [mm]	L [mm]	L2 [mm]	z [mm]
3/8	10	16	190	161 561 101	161 561 111	50	105	56	67
1/2	15	16	180	161 561 102	161 561 112	50	105	56	61
3/4	20	16	380	161 561 103	161 561 113	58	121	65	70
1	25	16	460	161 561 104	161 561 114	68	133	71	76
1 1/4	32	16	850	161 561 105	161 561 115	84	154	85	90
1 1/2	40	16	1080	161 561 106	161 561 116	97	164	89	94
2	50	16	1670	161 561 107	161 561 117	124	183	101	107
2 1/2	65	16	2950	161 561 108	161 561 118	166	233	136	144
3	80	16	3600	161 561 109	161 561 119	200	254	141	151
4	100	16	4150	161 561 110	161 561 120	238	301	164	174

Check valve type 562 PVC-U With solvent cement sockets Inch ASTM Inclusive 2 threaded valve ends NPT



Model:

- Spring loaded, spring made of stainless steel (1.4310)
- Spring available in other materials, see spare parts
- Designed for easy installation and removal
- Sealing at a minimum water column of 0.5m
- Vibration free even at high flow velocity
- Flow-optimized return cone, double guided
- For horizontal or vertical installation
- Compact installation length, same as ball valve type 546
- Z-length, end connectors and union nuts **not** compatible with type 360
- New DN65-DN100

Available from 2nd quarter 2011

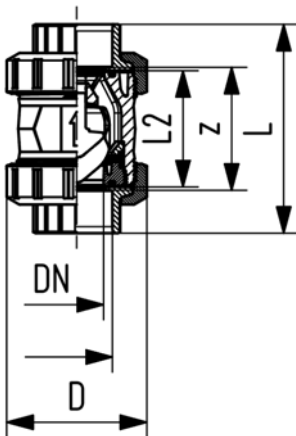

NPT [inch]	DN [mm]	PN	kv-value ($\Delta p=1$ bar) [l/min]	EPDM Code	FPM Code	D [mm]	L [mm]	L2 [mm]	z [mm]
3/8	10	16	190	161 562 101	161 562 111	50	105	56	67
1/2	15	16	180	161 562 102	161 562 112	50	105	56	61
3/4	20	16	380	161 562 103	161 562 113	58	121	65	70
1	25	16	460	161 562 104	161 562 114	68	133	71	76
1 1/4	32	16	850	161 562 105	161 562 115	84	154	85	90
1 1/2	40	16	1080	161 562 106	161 562 116	97	164	89	94
2	50	16	1670	161 562 107	161 562 117	124	183	101	107
2 1/2	65	16	2950	161 562 108	161 562 118	166	233	136	144
3	80	16	3600	161 562 109	161 562 119	200	254	141	151
4	100	16	4150	161 562 110	161 562 120	238	301	164	174

PVC-U ASTM/ANSI/BS

Silicone free/paintcompatible Cone check valves

Check valve type 561 PVC-U SF With solvent cement sockets Inch ASTM



Model:

- Silicone free / paint-compatible
- Designed for easy installation and removal
- Sealing at a minimum water column of 2m
- Vibration free even at high flow velocity
- Flow-optimized return cone, double guided
- For horizontal or vertical installation
- Compact installation length, same as ball valve type 546
- Z-length, end connectors and union nuts **not** compatible with type 360
- New DN65-DN100

Available from 2nd quarter 2011

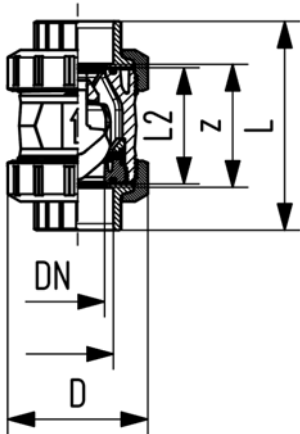

Inch	DN [mm]	PN	kv-value (Δp=1 bar) [l/min]	EPDM Code	FPM Code	D [mm]	L [mm]	L2 [mm]	z [mm]
3/8	10	16	190	161 561 241	161 561 251	50	105	56	67
1/2	15	16	180	161 561 242	161 561 252	50	105	56	61
3/4	20	16	380	161 561 243	161 561 253	58	121	65	70
1	25	16	460	161 561 244	161 561 254	68	133	71	76
1 1/4	32	16	850	161 561 245	161 561 255	84	154	85	90
1 1/2	40	16	1080	161 561 246	161 561 256	97	164	89	94
2	50	16	1670	161 561 247	161 561 257	124	183	101	107
2 1/2	65	16	2950	161 561 248	161 561 258	166	233	136	144
3	80	16	3600	161 561 249	161 561 259	200	254	141	151
4	100	16	4150	161 561 250	161 561 260	238	301	164	174

Check valve type 562 PVC-U SF With solvent cement sockets Inch ASTM



Model:

- Silicone free / paint-compatible
- Spring loaded, spring made of stainless steel (1.4310)
- Spring available in other materials, see spare parts
- Designed for easy installation and removal
- Sealing at a minimum water column of 0.5m
- Vibration free even at high flow velocity
- Flow-optimized return cone, double guided
- For horizontal or vertical installation
- Compact installation length, same as ball valve type 546
- Z-length, end connectors and union nuts **not** compatible with type 360
- New DN65-DN100

Available from 2nd quarter 2011

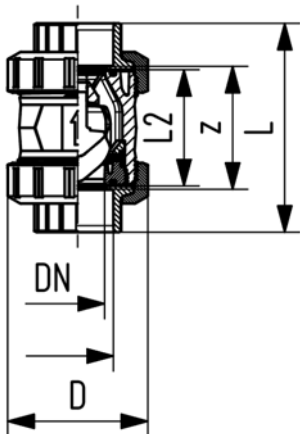

Inch	DN [mm]	PN	kv-value (Δp=1 bar) [l/min]	EPDM Code	FPM Code	D [mm]	L [mm]	L2 [mm]	z [mm]
3/8	10	16	190	161 562 241	161 562 251	50	105	56	67
1/2	15	16	180	161 562 242	161 562 252	50	105	56	61
3/4	20	16	380	161 562 243	161 562 253	58	121	65	70
1	25	16	460	161 562 244	161 562 254	68	133	71	76
1 1/4	32	16	850	161 562 245	161 562 255	84	154	85	90
1 1/2	40	16	1080	161 562 246	161 562 256	97	164	89	94
2	50	16	1670	161 562 247	161 562 257	124	183	101	107
2 1/2	65	16	2950	161 562 248	161 562 258	166	233	136	144
3	80	16	3600	161 562 249	161 562 259	200	254	141	151
4	100	16	4150	161 562 250	161 562 260	238	301	164	174

PVC-U JIS

Cone check valves

Check valve type 561 PVC-U With solvent cement sockets JIS



Model:

- Designed for easy installation and removal
- Sealing at a minimum water column of 2m
- Vibration free even at high flow velocity
- Flow-optimized return cone, double guided
- For horizontal or vertical installation
- Compact installation length, same as ball valve type 546
- Z-length, end connectors and union nuts **not** compatible with type 360
- New DN65-DN100

Available from 2nd quarter 2011

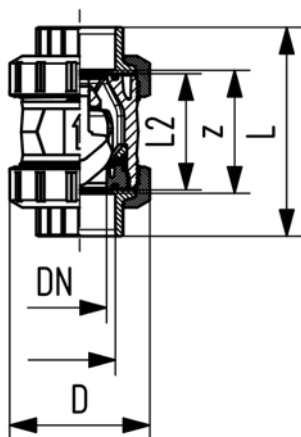

Inch	DN [mm]	PN	kv-value ($\Delta p=1$ bar) [l/min]	EPDM Code	D [mm]	L [mm]	L2 [mm]	z [mm]
1/2	15	16	180	161 561 302	50	95	56	64
3/4	20	16	380	161 561 303	58	110	65	72
1	25	16	460	161 561 304	68	123	71	79
1 1/4	32	16	850	161 561 305	84	146	85	94
1 1/2	40	16	1080	161 561 306	97	157	89	95
2	50	16	1670	161 561 307	124	183	101	107
2 1/2	65	16	2950	161 561 308	166	233	136	144
3	80	16	3600	161 561 309	200	254	141	151
4	100	16	4150	161 561 310	238	301	164	174

Check valve type 561 PVC-U With fixed flanges JIS



Model:

- Designed for easy installation and removal
- Sealing at a minimum water column of 2m
- Vibration free even at high flow velocity
- Flow-optimized return cone, double guided
- For horizontal or vertical installation
- Compact installation length, same as ball valve type 546
- Z-length, end connectors and union nuts **not** compatible with type 360

Available from 2nd quarter 2011

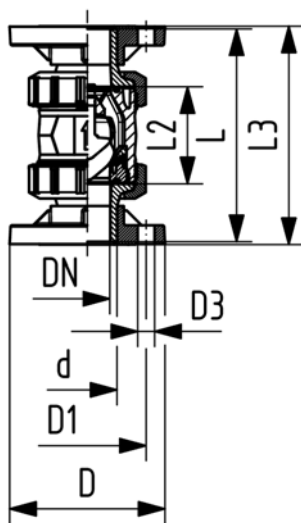

Inch	DN [mm]	PN	kv-value ($\Delta p=1$ bar) [l/min]	EPDM Code	D [mm]	D1 [mm]	D3 [mm]	L [mm]	L2 [mm]	L3 [mm]
3/4	20	16	380	161 561 323	100	75	15	170	65	172
1	25	16	460	161 561 324	130	90	19	190	71	187
1 1/4	32	16	850	161 561 325	140	100	19	190	85	190
1 1/2	40	16	1080	161 561 326	140	105	19	210	89	212
2	50	16	1670	161 561 327	160	120	19	240	101	234

PVC-U JIS

Check valve type 562 PVC-U With solvent cement sockets JIS



Model:

- Spring loaded, spring made of stainless steel (1.4310)
- Spring available in other materials, see spare parts
- Designed for easy installation and removal
- Sealing at a minimum water column of 0.5m
- Vibration free even at high flow velocity
- Flow-optimized return cone, double guided
- For horizontal or vertical installation
- Compact installation length, same as ball valve type 546
- Z-length, end connectors and union nuts **not** compatible with type 360
- New DN65-DN100

Available from 2nd quarter 2011

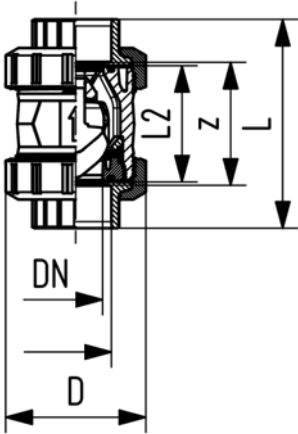

Inch	DN [mm]	PN	kv-value ($\Delta p=1$ bar) [l/min]	EPDM Code	D [mm]	L [mm]	L2 [mm]	z [mm]
½	15	16	180	161 562 302	50	95	56	64
¾	20	16	380	161 562 303	58	110	65	72
1	25	16	460	161 562 304	68	123	71	79
1 ¼	32	16	850	161 562 305	84	146	85	94
1 ½	40	16	1080	161 562 306	97	157	89	95
2	50	16	1670	161 562 307	124	183	101	107
2 ½	65	16	2950	161 562 308	166	233	136	144
3	80	16	3600	161 562 309	200	254	141	151
4	100	16	4150	161 562 310	238	301	164	174

Check valve type 562 PVC-U With fixed flanges JIS



Model:

- Spring loaded, spring made of stainless steel (1.4310)
- Spring available in other materials, see spare parts
- Designed for easy installation and removal
- Sealing at a minimum water column of 0.5m
- Vibration free even at high flow velocity
- Flow-optimized return cone, double guided
- For horizontal or vertical installation
- Compact installation length, same as ball valve type 546
- Z-length, end connectors and union nuts **not** compatible with type 360

Available from 2nd quarter 2011

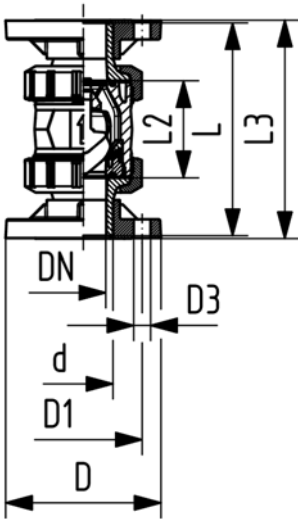

Inch	DN [mm]	PN	kv-value ($\Delta p=1$ bar) [l/min]	EPDM Code	D [mm]	D1 [mm]	D3 [mm]	L [mm]	L2 [mm]	L3 [mm]
¾	20	16	380	161 562 323	100	75	15	170	65	172
1	25	16	460	161 562 324	130	90	19	190	71	187
1 ¼	32	16	850	161 562 325	140	100	19	190	85	190
1 ½	40	16	1080	161 562 326	140	105	19	210	89	212
2	50	16	1670	161 562 327	160	120	19	240	101	234